



## SMALL VERTICAL VIBRATION ISOLATOR

THE SMALL VVI IS A COMPACT VERTICAL VIBRATION ARM USED WITH MANUALLY OPERATED HEADS AS WELL AS MEDIUM SIZED REMOTE STABILISED HEADS. THE SPRUNG LOADED ARM TOGETHER WITH AN ADJUSTABLE COMPRESION AND REBOUND DAMPER, SOFTEN VERTICAL VIBRATIONS TYPICALLY EXPERIENCED WHILE SHOOTING ON VEHICLES.

THE SMALL VVI WILL FIT ONTO ANY STANDARD MOY/MITCHELL PLATE AND CAN ACCEPT STANDARD MOY/MITHELL TYPE MOUNTS.

THERE IS AN OPTIONAL MOY EXTENSION PLATE TO ENABLE UNDERSLINGING OF REMOTE HEADS

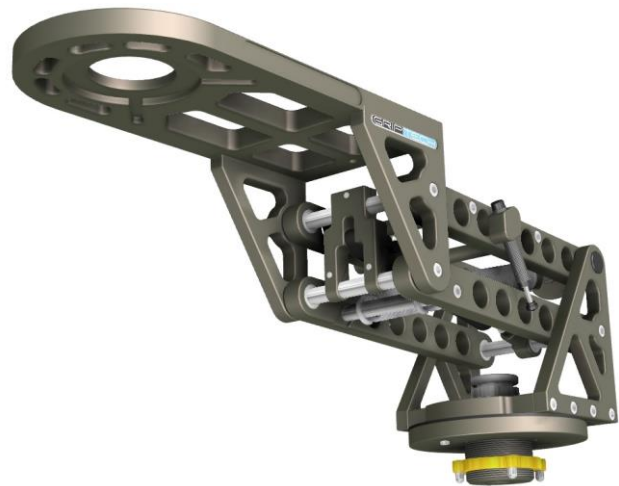

THE SMALL VVI ALSO HAS AN OPTIONAL 150MM BOWL FITTING FOR USE WITH FLUID HEADS.

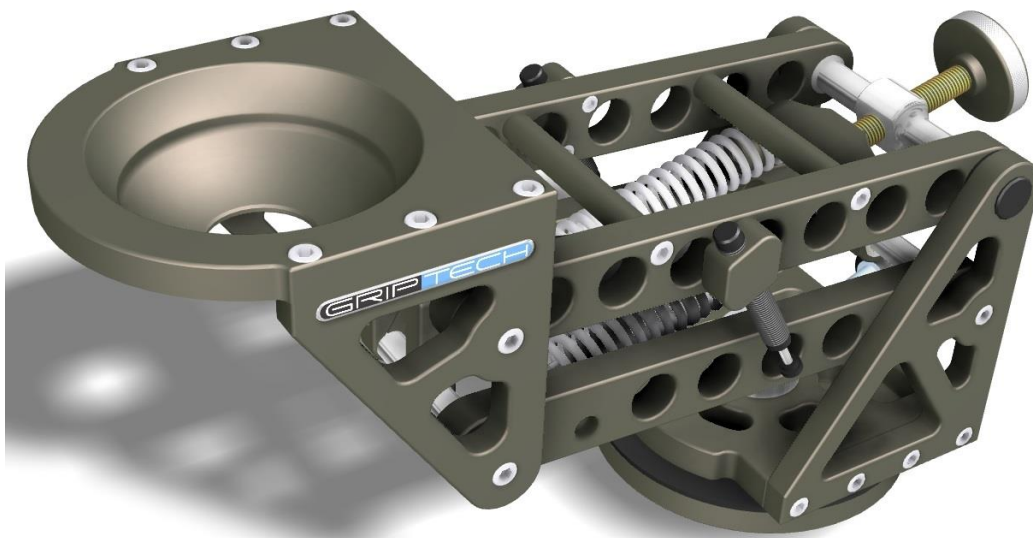

PAYLOAD- 18 TO 65 KG.THERE ARE THREE DIFFERENT SIZE SPRINGS THAT CAN EASILY BE CHANGED TO SUIT DIFFERENT CAMERA PACKAGES.

BELOW IS A GUIDE SHOWING THE PAYLOADS FOR THE THREE DIFFERENT SIZE SPRINGS IN RELATION TO THE LEVEL ADJUSTER KNOB SETTING. VVI ARM WILL BE LEVEL WHEN:

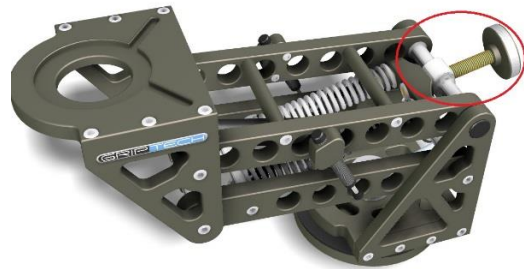

LIGHT SPRINGS	17.5KG
MEDIUM SPRINGS	32KG
HEAVY SPRINGS	50KG

LIGHT SPRINGS	24KG
MEDIUM SPRINGS	45KG
HEAVY SPRINGS	65KG

### SPRING CHANGE

NB BEFORE YOU CHANGE THE SPRINGS- WIND THE LEVEL ADJUSTER KNOB ALL THE WAY IN. THIS HAS TO BE DONE TO IN ORDER TO TAKE OUT THE SPRING SHAFT.

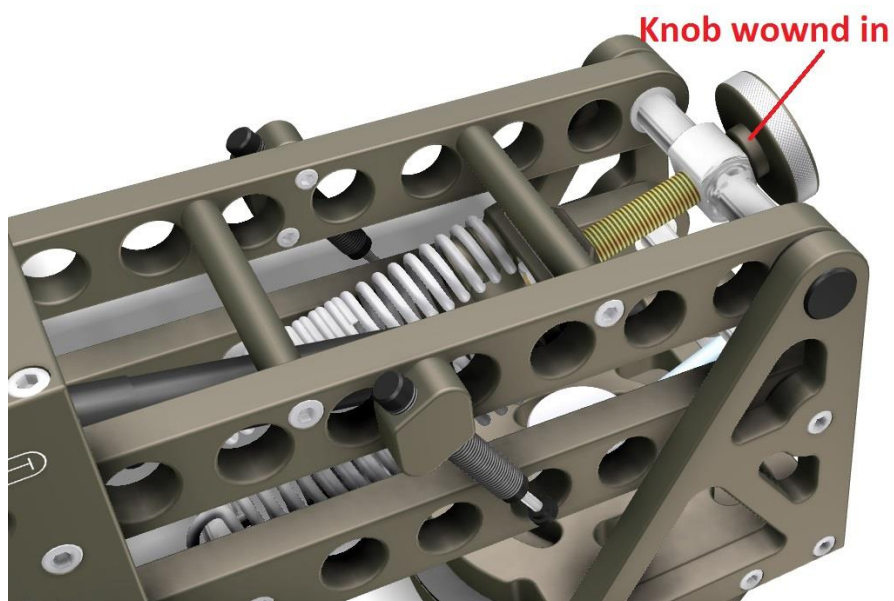

LOOSEN THE TWO SPRING SHAFT BOLTS AND LIFT THE ARM TILL YOU CAN PULL OUT THE SPRING SHAFT.

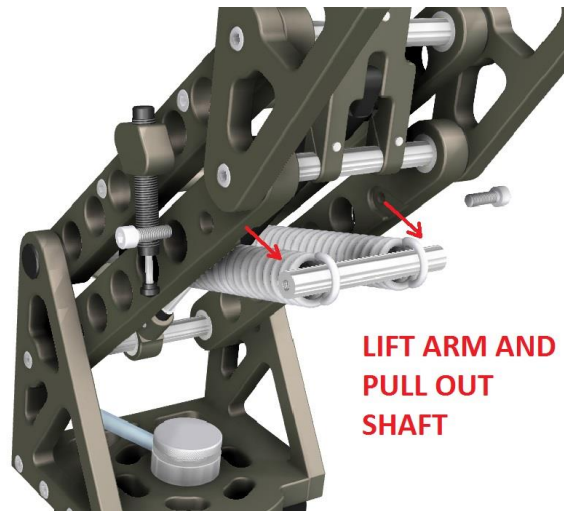

UNBOLT THE SPRINGS

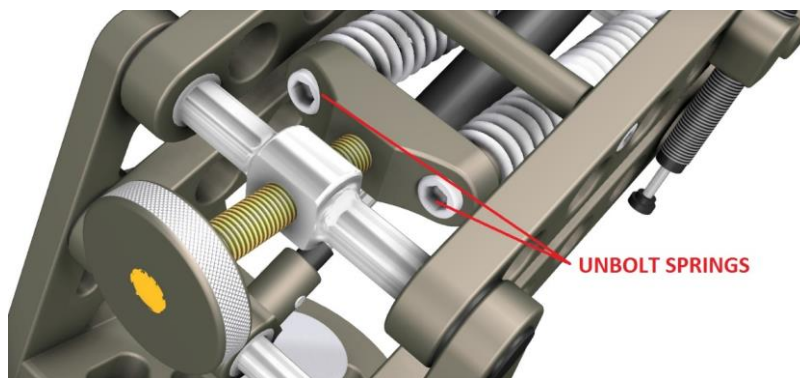

AFTER CHOOSING AND INSTALLING SUITABLE SPRINGS, ENSURE THAT THE SPRING BRACKET IS ORIENTATED CORRECTLY BEFORE PROCEEDING.

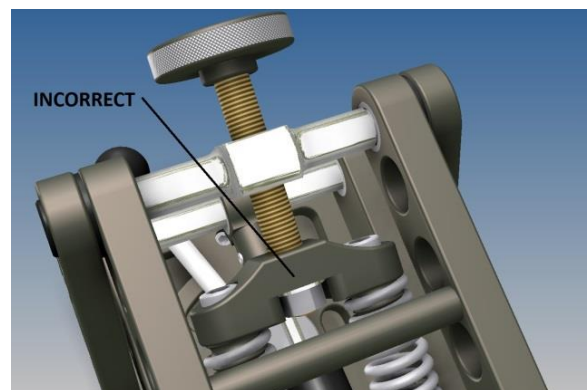
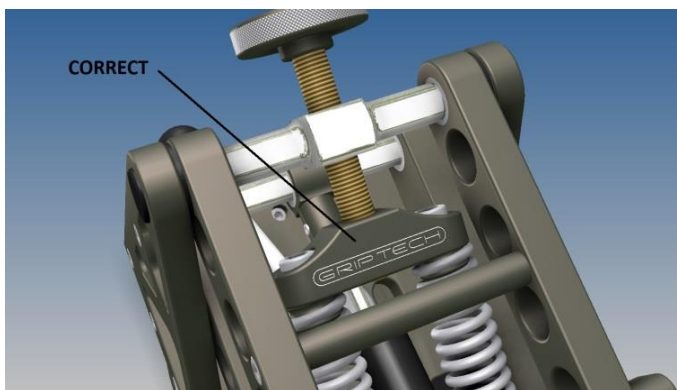



MOUNT THE CAMERA PACKAGE AND WIND THE LEVEL ADJUSTER KNOB IN OR OUT TO RAISE OR LOWER THE ARM TO A LEVEL POSITION.

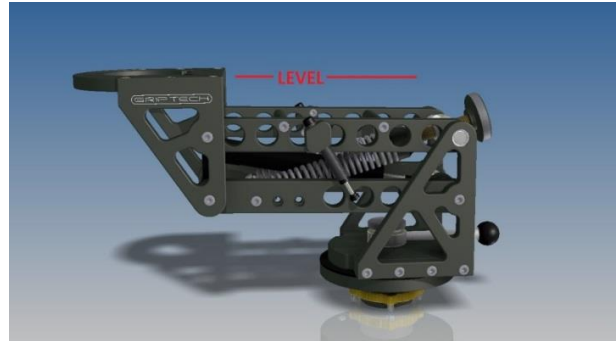
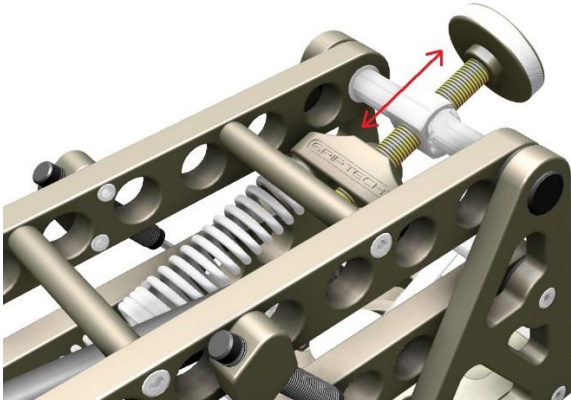

THE FLIGHT CASE HAS CAVITIES FOR THE EXTENSION PLATE AND THE 150MM BOWL FITTING. DIMENSIONS 84 X 43 X 17CM -WEIGHT 16KG (INCLUDING EXTENSION PLATE AND BOWL)



WORKING TRAVEL UNDER LOAD.

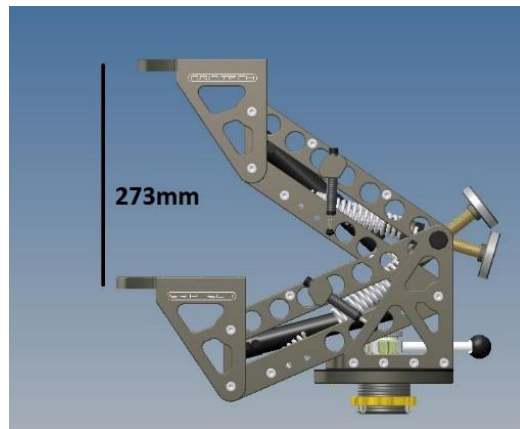

DIMENSIONS

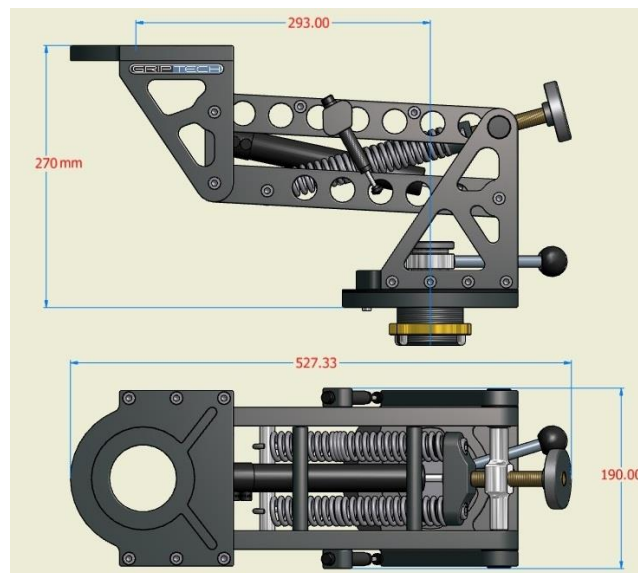

QUICK ACTION SWIVEL FEATURE ENABLES YOU TO ROTATE THE ARM 360 DEGREES AND LOCK.

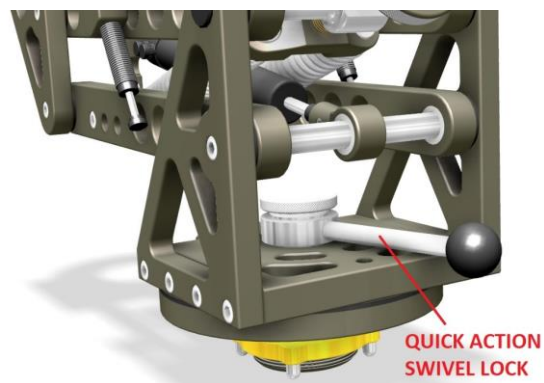

FINE TUNING OF THE COMPRESSION AND REBOUND ON THE DAMPER. WITH CAMERA PAYLOAD ATTACHED, PUSH ARM DOWN HARD AND RELEASE. THE ARM SHOULD REBOUND TO ITS NEUTRAL POSITION WITHOUT BOUNCING. IDEALLY THE ARM SHOULD COME TO REST IN ABOUT 2 TO 3 MOVES. SET COMPRESSION AND DECOMPRESSION KNOBS BY SMALL AMOUNTS AT A TIME. TENSION AND COMPRESSION SHOULD BE SET TO THE SAME VALUES. THEY ARE SCALED FROM 1 TO 10 ON EACH ADJUSTER KNOB. 1 BEING THE WEAKEST AND 10 BEING THE STIFFEST.

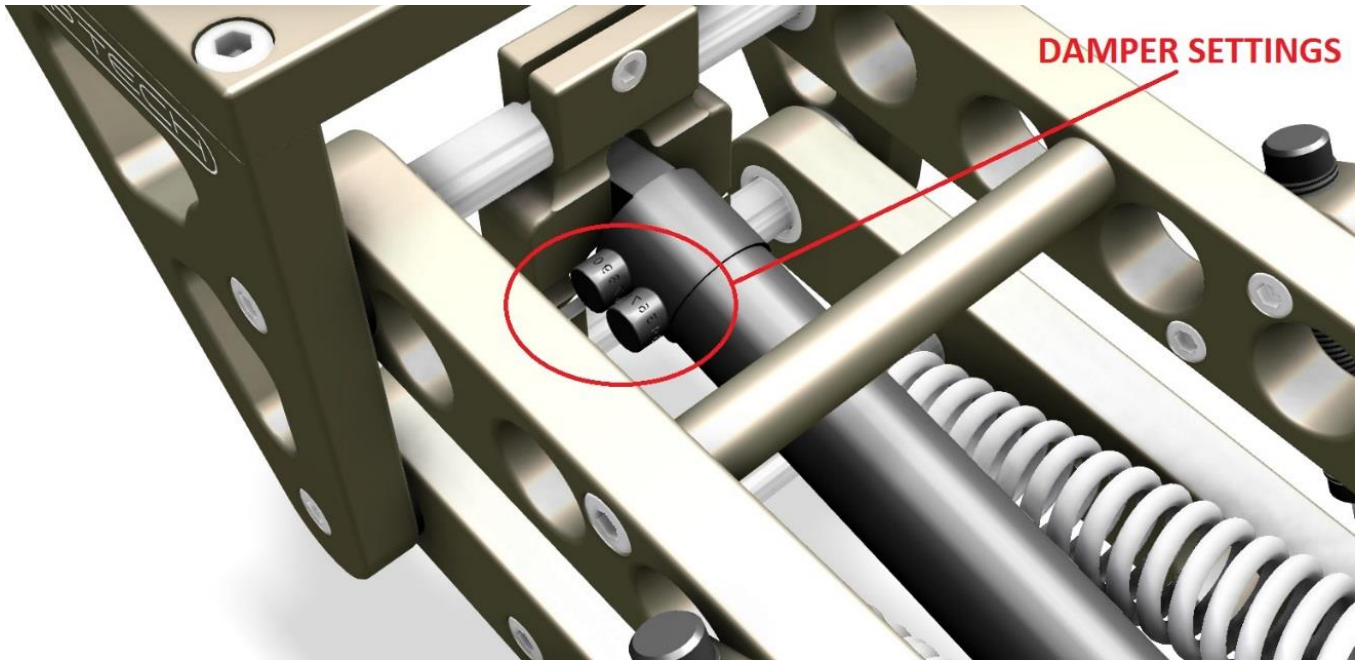

MANY CUSTOMERS ARE USING THE STANDARD GRIPTECH VI MOUNTED TO THE SMALL VVI.





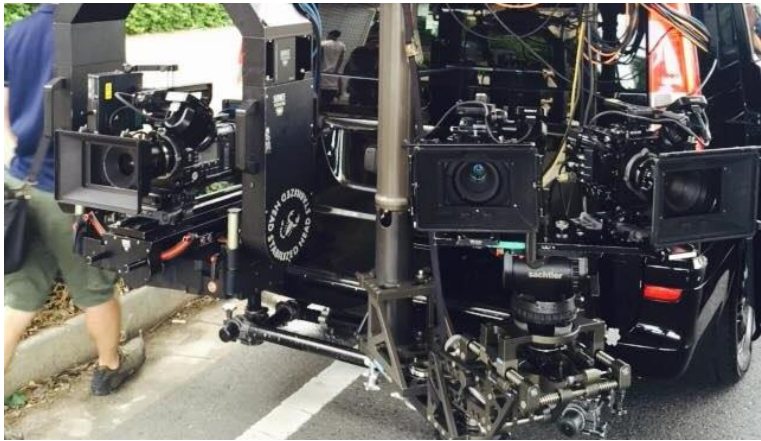
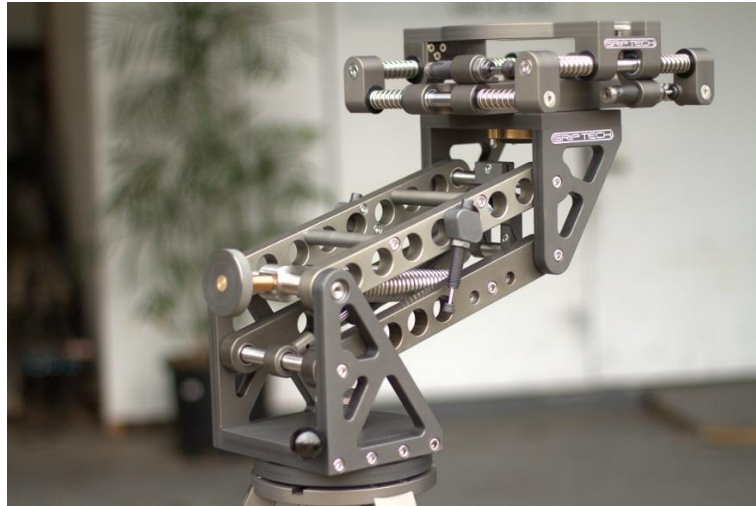

**GRIP** TECH